

TAPER

BAR TABLE - G72BT

CAFE TABLE - G72T



Design: Mark Daniel, 2021

Materials: Powder coated steel upright and base, veneered plywood tabletop

Certifications: Meets or exceeds ANSI/BIFMA X5.5. Meets or exceeds ANSI/BIFMA M7.1 VOC emissions standards for office furniture.

Care & Cleaning: Clean and dust with a damp cloth.

Warranty: 3 years

VENEER OPTIONS:



natural ash

POWDER COAT OPTIONS:



black

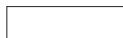

white

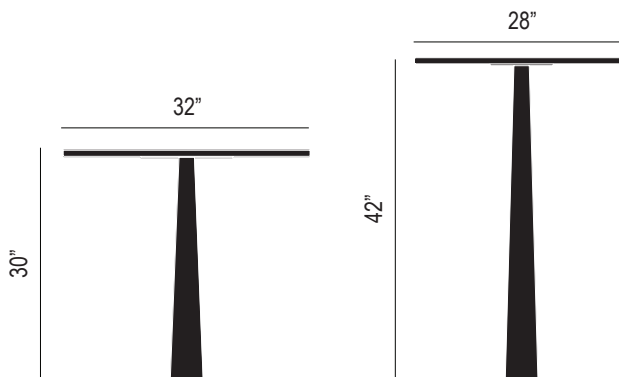

Weight: Cafe Table 41.4 lbs, Bar Table 44.8 lbs

Packaging: Double walled cardboard, internal blocking.

Box 1: 37.2"W x 0.2"H x 37.2"D Box 2: 4.5"W x 30"H x 4.5"D Box 3: 22"W x 2"H x 22"D

Box 1: 29.1"W x 0.2"H x 29.1"D Box 2: 4.5"W x 41"H x 4.5"D Box 3: 22"W x 2"H x 22"D

Pieces per box: 1

Assembly: Simple assembly required

Duty Code: 9403.40.90.80

Made in: China